

Monsoon Features and Benefits

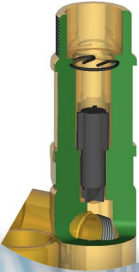

Automatic Switching

- Pressure Switch – automatically stops the pump and re-pressurises the system (Universal)
- Flow Switch – automatically starts the pump when flow exceeds 0.6 litres/min (Standard)

Flexible Hoses

- 22mm x 300mm push-in, anti-vibration flexible hoses
- Integral isolating valves
- ¼ BSP threaded connection to pump

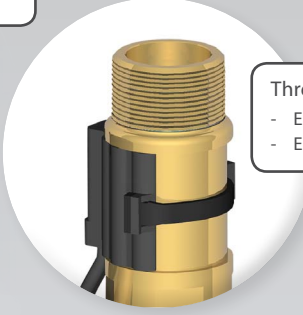
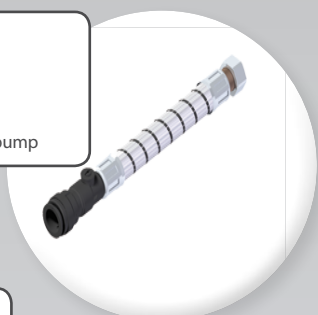

Threaded Connections

- Ease of installation
- Ease of maintenance

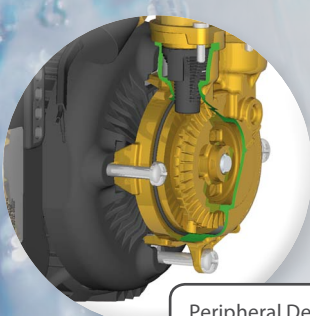

Peripheral Design

- Pressure efficient
- Compact size
- System friendly – reduces potential to airlock

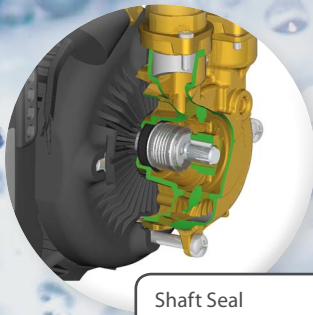

Shaft Seal

- Hard faced carbon/silicon carbide seal
- Longer Life

Every component of the Monsoon range has been designed and improved to enhance the already high levels of reliability, performance and efficiency. Monsoon's brass bodied construction enables reliable and efficient performance for a wide range of applications.



Anti-Vibration Feet

- Reduces noise transmission

Safety

- Low voltage – 9v for all switching
- SELV advanced control systems
- Pre-wired with 1.5m cable – no need to access terminal box

